



2011

**9th INTERNATIONAL CONFERENCE
ON ELECTRICAL FUSES AND THEIR APPLICATIONS**

**NEW SOLUTIONS FOR OVERCURRENT PROTECTIVE
DEVICE DISCRIMINATION REQUIREMENTS**

Matt Darr, Robert Douglass, Vince Saporita

New Solutions for Overcurrent Protective Device Discrimination Requirements

Matt Darr, Robert Douglass, Vince Saporita

Cooper Bussmann, P.O. Box 14460, St. Louis, MO 63178 USA

Abstract

The US National Electrical Code® (NEC®) [1] has initiated requirements for discrimination (selective coordination) in emergency, legally required, and critical operations power systems. While this required discrimination increases the reliability of critical, life-safety-related loads, it has been a challenge to design and install systems that discriminate with currently available fusible and circuit breaker equipment. Challenges included equipment footprint (size), interrupting rating, short-circuit current rating, and cost. Solutions led to a new UL Class fuse, a new load-break disconnect switch with the footprint of an MCCB, and a new MCCB-sized panelboard, all specifically designed to meet the discrimination requirements.

Keywords: overcurrent protective device.

Introduction

There are certain life-safety-related loads that are so critical, so important, that we go to great lengths to make sure that they are not interrupted. Examples of these life-safety-related loads are egress lighting for evacuation of a building, exit signs, fire detection and alarm systems, elevators, fire pumps, and many health care loads. We take special care of these systems/loads. Periodic testing, maintenance and record retention is required. Alternate power sources must be utilized. Emergency wiring must be kept separate from non-emergency wiring. Automatic transfer switches with sophisticated sensors, monitors, and controls are utilized.



Fig. 1: The NEC® requires discrimination for life-safety-related loads, such as for the emergency lighting for evacuation of this arena.

However, before adoption of the 1993 National Electrical Code®, there were no requirements for discrimination for any critical life-safety-related loads, even where large crowds gathered, such as stadiums, arenas (Fig. 1), high-rise office buildings, universities, and hospitals. So, there was no NEC® requirement, for example, that prohibited a short-circuit in a light fixture in the basement of a sports arena from opening overcurrent devices all the way up to and including the main for the entire arena. See Fig. 2.

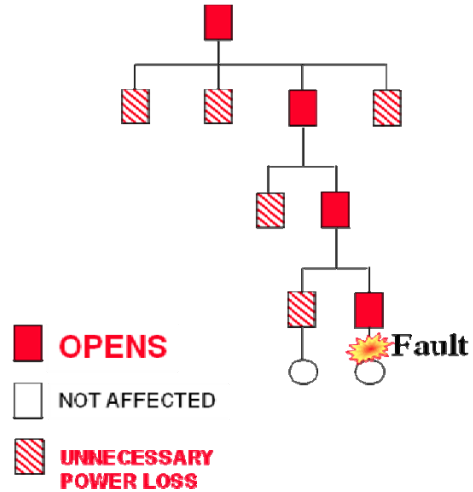

Fig. 2: This one-line diagram shows a fault on a branch circuit opening not only the branch overcurrent protective device, but also the sub-feeder, feeder, and main devices (solid boxes). There is an unnecessary power loss to numerous other loads (hashed boxes)

And, if an emergency generator and transfer switch were utilized, the transfer switch could switch the load to the emergency generator, but if the short still existed, a similar cascading of overcurrent devices could occur, again blacking out the entire building.

The 1993 National Electrical Code® initiated the concept of required discrimination.[2] It began with a requirement for complete discrimination of elevator circuits. In essence, an overcurrent in one elevator circuit is not allowed to open any other elevator circuits. So, an overcurrent in one elevator will not take out any other or even all the elevators. See Fig. 3.

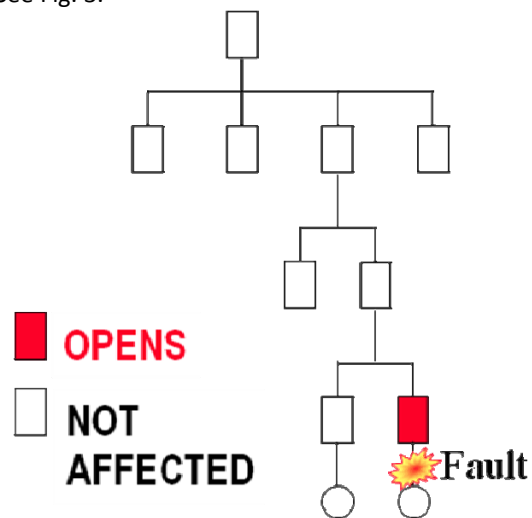

Fig. 3: This one-line diagram shows a fault in one elevator circuit opening only one elevator branch circuit overcurrent device. No other elevators are affected.

The 1993 National Electrical Code® change resulted in development, by at least four manufacturers, of elevator control panels utilizing fusible disconnect switches with shunt-trip capability. See Figure 4.



Fig. 4: This figure shows a fusible disconnect switch with shunt-trip capability so that all power to the elevator can be removed before the application of water in the elevator shaft.

The fuses in a traditional fused switch could, of course, easily discriminate with upstream subfeeder, feeder, and main fuses. The novel twist however was that shunt-trip capability was necessary to meet Mechanical Code requirements that all power be removed from the elevator shaft before the application of water (sprinklers) in the shaft. (So, if there were ever a fire in the elevator shaft, the elevator would travel to a “safe” floor, the doors would open, a signal would be sent to the shunt-trip switch, opening the shunt-trip switch, and then water would be released to douse the fire in the elevator shaft.)

Shunt-trip circuit breakers are available, but it is very difficult, or expensive to get them to discriminate with larger, upstream circuit breakers. As a result, the fused shunt-trip switch elevator panels have now become the standard design throughout the country.

In the 2005 National Electrical Code® requirements were introduced for complete discrimination of emergency[3] and legally required standby system[4] overcurrent protective devices. The emergency and legally required standby loads, typically served out of standard circuit breaker panelboards, include emergency lighting, smoke evacuation, exit signs, fire detection and alarm systems, and fire pumps.

While it was fairly easy to implement complete discrimination for elevator circuits, because the elevator circuit switch was typically a stand-alone unit, mounted in the elevator room, implementing

complete discrimination for emergency and legally required standby systems was an interesting challenge. The challenge wasn't whether or not it could be accomplished from an engineering perspective, for it has been standard practice for military, business centers, and banking centers for decades. It was whether or not it could be accomplished in the same amount of space and without adding considerable cost as compared to non-discriminating systems.

The Challenge

For those wishing to meet the discrimination requirements by utilizing an all fusible system, panel size was an issue. A panelboard utilizing fusible switches has always been larger than panelboards utilizing circuit breakers. See Fig. 5. For example a 200 ampere, 480 volt, molded case circuit breaker panel is typically 50 cm (20”) wide by 14.6 cm (5.75”) deep. The typical fusible panelboard is 91.4-111.8 cm (36”-44”) wide by 26.4 cm (10.4”) deep. It is a difficult “sell” to convince an architect or consulting engineer to allow so much more room in their building.



Fig. 5: These pictures illustrate the typical difference in size that existed between a fusible panelboard on the left and a molded case circuit breaker panelboard on the right.

Some designers prefer to use thermal-magnetic molded case circuit breakers wherever possible. One method available to them that is often utilized to obtain or improve the discrimination of circuit breakers is to increase the case size of the larger, upstream circuit breaker, while keeping the trip rating the same. For example, if a 400 amp frame, 400 amp trip feeder circuit breaker were supplying a 20 ampere circuit breaker, the two would discriminate to about 4,000 amperes, (assuming the 400 ampere circuit breaker's instantaneous trip is about 10 times the frame rating of the circuit breaker). If an 800 amp frame circuit breaker were

to utilize a 400 ampere trip, the 20 amp branch circuit breaker and the 800 amp frame/400 amp trip would discriminate to about 8,000 amperes. Such an increase is often all that it takes to obtain the necessary discrimination. The problem is that the 800 amp frame circuit breaker is considerably more expensive than the 400 amp frame circuit breaker, and it takes up more space in a panelboard.

Another method that is very often utilized is to remove the instantaneous trip on upstream circuit breakers and adjust their short-time delay settings to provide the required discrimination.

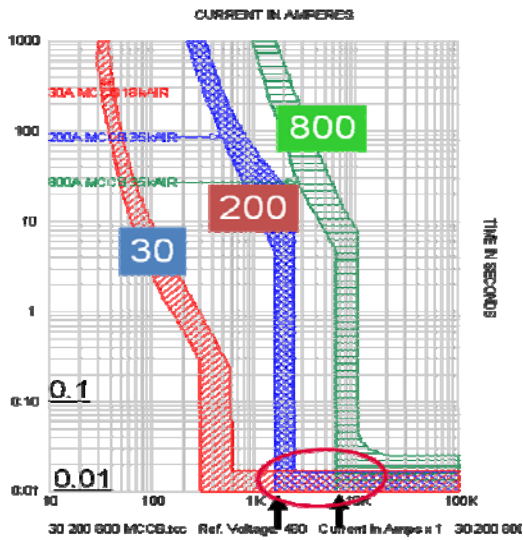

Fig. 6: This figure shows the overlap of three thermal-magnetic circuit breakers employing an instantaneous trip. A fault on the load side of the 30 ampere branch circuit overcurrent device exceeding about 7,000 amperes will open the 30 amp, the 200 amp, and the 800 ampere devices, for a total system blackout.

Figures 6 and 7 illustrate the benefits of employing short-time delay to achieve discrimination. Fig. 6 shows the overlap of three thermal-magnetic circuit breakers employing an instantaneous trip. A fault on the load side of the 30 ampere branch circuit overcurrent device exceeding about 7,000 amperes will open the 30 amp, the 200 amp, and the 800 ampere devices, for a total system blackout. Fig. 7 shows the affect of utilizing short-time delay on the 200 amp and 800 amp upstream circuit breakers. With clear “light” between the circuit breaker curves, discrimination is achieved up through the interrupting ratings of the devices. Unfortunately, on the negative side, circuit breakers with no instantaneous, and without an instantaneous override, and having short-time delay are often quite expensive as compared to standard thermal-magnetic molded case circuit breakers. These types of circuit breakers, often air-frame or power circuit breakers, are usually much larger than their molded case cousins. Finally, when short-time delay is utilized, (and it is used every day for hospitals, banking and money centers, continuous process industrials, military bases, etc.) the equipment it is protecting must be short-circuit rated for the length of the short-time delay. For example, if a 800 ampere power circuit breaker, with a short-time delay set at 30 cycles, is protecting a transfer switch, that transfer switch must be able to withstand the full available short-circuit current for the full 30 cycles. This may result in the upsizing of the transfer switch so that it is capable of handling the available fault current for the extended period of time.

To summarize the “Challenge”, discrimination can be achieved, using both fused systems and circuit breakers systems, but achieving discrimination resulted in larger and very often more costly equipment than is required for systems without discrimination.

The Solution

It became obvious that a different kind of fusible solution was needed for those designers that preferred fuses, (and maybe some designers that prefer circuit breakers would be willing to switch to fusible designs?). Before starting the design however, visits with users and specifiers determined that they wanted (1) Everything to be IP2X (fingersafe). (2) To make sure that fuses couldn’t be removed while they were energized. (3) High short-

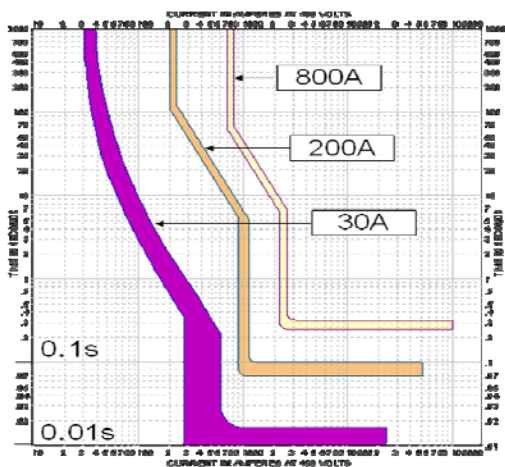

Fig. 7: This figure shows the affect of utilizing short-time delay on the 200 amp and 800 amp upstream circuit breakers. With clear “light” between the circuit breaker curves, discrimination is achieved up through the interrupting ratings of the devices.

circuit current ratings. (4) Fusible switch panelboards with the size, look and feel of circuit breaker panelboards. (5) Ampere rating rejection so that a 30 ampere fuse could not be replaced into a circuit calling for a 20 ampere fuse. And (6) Full discrimination must be achieved.

The need to meet the requirements for discrimination in the NEC® and the desire to provide users/designers with the features/benefits that they wanted resulted in new designs for fusible switches and panelboards that would accept them. The fuses that were chosen were UL Class CF.[5] They are current-limiting (Class J[6] current limitation requirements), finger-safe rated for 600 volts AC with interrupting rating of 300,000 amperes (at 600 volts AC). The first family of Class CF fuses had time-delay characteristics and was introduced with yellow labels. Another family of Class CF fuses has since been introduced (with a blue label) that is fast-acting, with a 600 volt DC rating (in addition to the 600 volt AC rating). (It is especially useful when used on the load side of UPS systems, providing very quick isolation of a problem circuit before the UPS system shuts down.) Fig. 8 shows the three “case” sizes of time-delay Class CF fuses, 100A, 60A, and 30 A. Two fuses of each case size are shown. The one on the left is an indicating version, while the one on the right is non-indicating. Fig. 9 shows the top, side, and front views of the fuse. The “D” dimension changes with the ampere rating so that ampere rating rejection can be accomplished.



Fig. 8: This figure shows time-delay Class CF fuses in three case sizes, 100, 60, and 30 amperes.

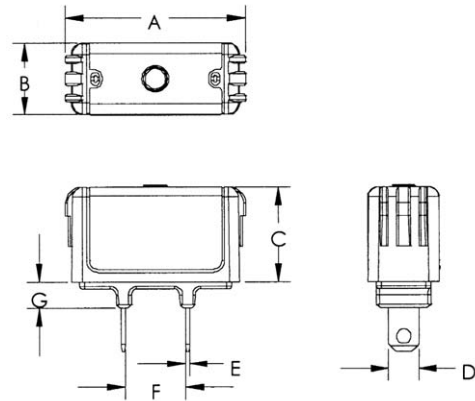

Fig. 9: This Figure shows the top, side and front views of the Class CF fuse. The “D” dimension increases with the ampere rating of the fuse in order to provide ampere rating rejection.

The Class CF fuse now needed a UL 98 disconnect switch [7] that could accommodate its IP2X rating. Fig. 10 shows the side view of the resulting disconnect switch and its matching time-delay Class CF fuse. Fig. 11 shows a 3-pole configuration of the fused switch with time-delay Class CF fuses and a 1-pole configuration with a fast-acting Class CF fuse. As the switch is closed, an internal pin drops down through the hole in the blade of the fuse. (See Fig. 9 for the location of the hole.) This prevents the fuse from being removed while the switch is energized. As the switch is being turned to the off position, the internal pin is removed, making it possible for the fuse to be removed in the de-energized (off) position.



Fig. 10: This figure shows the UL 98 disconnect switch matched up with the Class CF fuse.



Fig. 11: The UL 98 disconnect switch is available in 1, 2, and 3 pole configurations. The 3-pole switch is shown with time-delay Class CF fuses while the 1-pole switch is shown with a fast-acting Class CF fuse

The switches include an open fuse indication light as an aid for maintenance personnel, as well as provisions for installing a lock to meet lock-out-tag-out safety requirements. See Fig. 12. Of great significance is that these switches are “load break” with horsepower ratings. They are full UL 98 disconnect switches. Another key point is that they are 25 mm (1”) wide, to match up with circuit breakers.

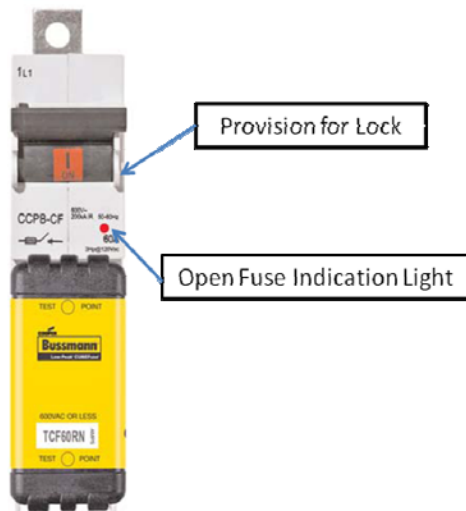

Fig.12: The disconnect switch for Class CF fuses has a built-in open fuse indicator light as well as provisions for installing a lock to meet lock-out-tag-out safety requirements.

With fusible disconnects available in a 25 mm (1”) width, a panelboard was developed with dimensions to match competitive circuit breaker panels. 600 volt panels, up through 400 amperes are 50 cm (20”) wide by 14.6 cm (5.75”) deep. Fig. 13 shows a 200 ampere, 600 volt panelboard with a fused switch main. These panelboards are available with short-circuit current ratings of either 50kA or 200kA. There are provisions for storing spares. See the row of spare time delay Class CF fuses across the bottom of the panel.



Fig. 13: This figure shows a 200 ampere, 600 volt panelboard with a 200 ampere main fused switch with 200 ampere Class J time-delay fuses. Spare fuses are located in the horizontal row across the bottom of the panel. Panel can have either a 50kA or 200kA short-circuit current rating.

This panelboard makes it easy for the designer/installer to achieve discrimination (simply maintain a 2:1 ratio between line side fuse and load side fuse) with the same look, feel, and footprint (size) of a circuit breaker panel.

Conclusion

Changes to the NEC® to require full discrimination for certain life-safety-related loads in places of assembly, such as hotels, stadiums, arenas, universities, and high rise office buildings created a challenge for engineers/installers. They were able to achieve full discrimination using both fuses and circuit breakers, but the available solutions were generally larger and more costly than similar systems that did not achieve full discrimination.

A new UL fuse Class was developed (Class CF), along with a 25 mm (1”) wide, UL 98, load break disconnect switch that would fit into a 50 cm (20”) wide by 14.6 cm (5.75”) deep panelboard. This combination met the demands of the engineers/installers which were (1) Everything had to be IP2X (fingersafe). (2) Fuses couldn’t be removed while they were energized. (3) High short-circuit current ratings. (4) Fusible switch panelboards with the size, look and feel of circuit breaker panelboards. (5) Ampere rating rejection

so that a 30 ampere fuse could not be replaced into a circuit calling for a 20 ampere fuse. And (6) Full discrimination must be achieved.

References

- [1] National Electrical Code® (NEC®) National Fire Protection Association®, One Batterymarch Park, Quincy, Massachusetts 02169-7471
- [2] Section 620-51(a), 1993 National Electrical Code®, Page 660
- [3] Section 700.27, 2005 National Electrical Code®, Page 567
- [4] Section 701.18, 2005 National Electrical Code®, Page 570
- [5] Subject 248-17, Underwriters Laboratories Inc., Outline of Investigation for Low Voltage Fuses-Part 17: Class CF Fuses
- [6] UL Standard for Safety for Low-Voltage Fuses-Part 8: Class J Fuses, UL 248-8
- [7] UL Standard for Safety for Enclosed and Dead-Front Switches, UL 98