

The logo for ICEFA (International Conference on Electrical Fuses and Their Applications) features the letters 'ICEFA' in a bold, yellow, sans-serif font. The letters are contained within a green rectangular border with a black outline. The background of the entire cover is a vibrant, abstract graphic with a color gradient from yellow and orange at the top to blue and green at the bottom. It features a central, glowing, cylindrical object that resembles a fuse holder or a high-voltage component, surrounded by concentric, wavy lines that create a sense of depth and energy.

ICEFA

2011

**9th INTERNATIONAL CONFERENCE
ON ELECTRICAL FUSES AND THEIR APPLICATIONS**

**INSULATED HV FUSE HOLDER
WITH VOLTAGE INDICATION**

Borut Česnik, Zoran Nedoh

Insulated HV fuse holder with voltage indication

Borut Česnik⁽¹⁾, Zoran Nedoh⁽²⁾

⁽¹⁾ IMP-tentelekom, d.o.o., Vojkova cesta 58, 1000 Ljubljana, Slovenia, b.cesnik@imp-tentelekom.si

⁽²⁾ TSN, d.o.o., Šentiljska cesta 49, 2000 Maribor, Slovenia, z.nedoh@tsn.si

Abstract

The most common protection of a power transformer in an end distribution transformer substation are MV fuses on proper fuse holder. Uninsulated parts are weak points of a transformer substation (danger of contact with live parts, weather influences, little animals etc.). Insulated fuse housing type VOH allows the design of a transformer substation with a completely insulated 20 (10) kV part. Voltage indication offers an additional security to the operator. The fuse housing is manufactured out of high quality insulating material. The fuse holder is covered with earthed metal casing.

Keywords: electric fuse, insulated fuse holder, overvoltage.

1. Introduction

Protection of distribution transformers is often carried out with HRC HV fuses and switches. Distribution transformers of up to 160 kVA rated power are protected against short-circuit current with built-in HRC HV fuses. HV fuse is mounted to the fuse holder which is installed to the transformer. Fuse holder comes in various designs. Common to all fuse holders is that they are not insulated. The fuse itself is also not insulated.

At the mentioned designs of fuse holders exists danger of touching parts under high voltage and malfunction due to access of small animals.

New trends in manufacturing of distribution transformers dictate new designs of HV connection type plug-in.

As example: transformers type HTI3 from manufacturer ETRA33 has HV connections carried out through connector bushings. The construction of such connector allows new solutions which improves safety in transformer substations.

Solution to listed deficiencies is single pole insulated HV fuse holder – VOH.

2. Technical characteristics of VOH

Characteristics of single pole insulated HV fuse holder – VOH.

- Completely insulated design, which allows maintenance of substation without danger of touching parts under high voltage,
- Voltage indication in cable connector (VOH01),
- Electric signalization of fuse operating with possibility to install micro-switch for remote signal transfer of the fuse condition (VOH02),
- Use of standard HRC HV fuse,
- Installation of various designs directly on the transformer's cover,
- Simple manipulation respectively exchange of the fuse,
- Ready for usage on transformers with connector bushings (SIST EN 50181 – design with insulated cable connector),
- Ready for connection with cable connector (interface C-630 A-bolted T plug) according to SIST EN 50181 which also allows installation of surge arrester,
- It does not need any additional maintenance,
- Voltage indication on transformer bushing,

- Possibility of earthing without dismantling cable connector (head) on connection point of the holder



Figure 1: Insulated HV fuse holder VOH 01 (design by TSN) mounted on a transformer's cover (50 kVA).

Rated voltage of the fuse holder is 24 kV, but it can also be used for lower voltages. Rated current is 30 A. Fuse holder with rated current 100 A has a special design of contact connections.

On cable connector is a mechanical signalization of voltage indication (SIST EN 61958:2002; SIST EN 61243-5:2002).

Built-in voltage indicators type IN5 (design by TSN) allow local signalization of voltage indication on cable.

Voltage indicator IN5 (Figure 2) receives the signal from indication on the fixed part of the fuse holder.

The cable is earthed to the earthing screw on the construction. The whole device itself is earthed to the main earthing of the substation.



Figure 2: Voltage indication on VOH 01 carried out with IN5

In case of mounting voltage indicator IN6, an own power supply is necessary ($<1W$, $24-48V_{DC}$; $90-220 V_{DC,AC}$). This type allows remote signal transfer of presence respectively absence of voltage indication.

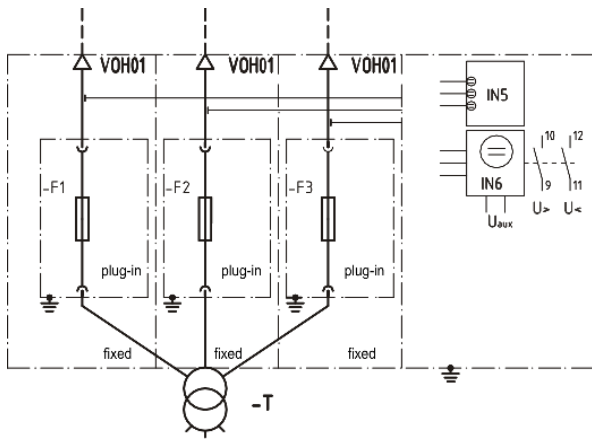

Figure 3: Schematic presentation of fuse holder function type VOH01

Fuse holder type VOH is designed for installation of standard HRC HV fuses with maximum diameter of insulation tube of 85 mm and length of insulation tube of 442 mm. Diameter of fuse connection is 45 mm.

Fuse holder design type VOH 2 is used when one wishes to know the fuse condition. VOH 2 is equipped with voltage indicator on cable connector as well on bushing connector on transformer.

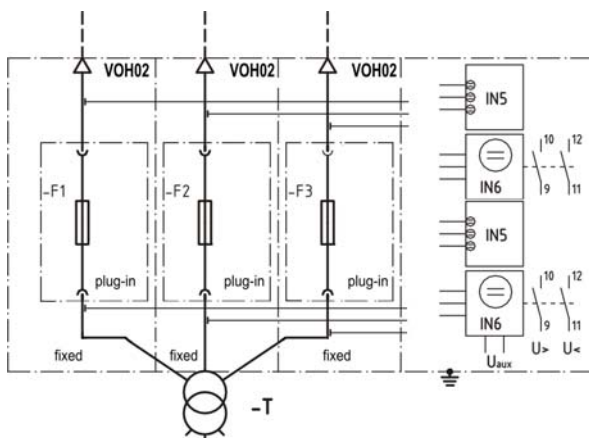

Figure 4: Schematic presentation of fuse holder function type VOH02

TABEL1
TECHNICAL DATA

Type	VOH01 (02)
Rated voltage	24 (12) kV
Rated power frequency withstand voltage	50 kV
Rated lightning impulse withstand voltage	125 kV
Rated current	30 (100) A
Rated peak withstand current	50 kA
Rated short time withstand current	20 kA
Protection degree (IEC 60529)	IP 54
Width	225 mm
Depth	270 mm
Height	725 mm
Fuse characteristics	
- Rated current	up to 100 A
- width of insulation tube	max. 85 mm
- length of insulation tube	442 mm
- diameter of the fuse connection	45 mm
- maximum length	512 mm

The Fuse holder is suitable for areas with polluted atmosphere and areas with danger of touching “live parts” that are under high voltage.

Therefore it perfectly matches for installation in prefabricated compact transformer substation with external manipulation. The exchange of fuses itself is very simple and easy.

3. Design of fuse holder VOH

The installation of fuse holder on the transformer is designed to assure all required electrical characteristics. Fuse holder type VOH consists out of fixed part, which is mounted on the transformer’s cover and withdrawable part, which contains a fuse (Figure 5).



Figure 5: Structure of fuse holder type VOH 01

Fixed part is made out of insulating epoxy resin. With a system of holder it is mounted on the transformer's cover.

On the holders are earthing elements. When mounting the fuse holder, one presses out all the air between silicon insertion and insulating materials. The mechanical design assures a strong fixation and protects HV connections on transformer against damages.

Into the fixed part the withdrawable part is inserted. In the withdrawable part are jaws of the main withdrawable contacts and contacts which hold the fuse. The withdrawable contacts are designed for a burden of continuous current of 400 A. Because usage in closed housing which disables the air circulation a rated current 30 A (100 A) is defined.

All internal copper connections are over dimensioned to divert the heat as much as possible.

The withdrawable part is made out of insulation material and covered in a earthing metal cover (option). In the interior is a fuse, a system of withdrawable contacts and a silicon washer.



Figure 6: Detail of upper contacts



Figure 7: Fuse holder type VOH01 with elements for installation



Figure 8: Fuse holder type VOH01 with connection Type C (EN5018), bolted T-plug, and mounted surge arresters

4. Application

Single pole insulated fuse holder is designed for installation of HV HRC fuses for transformer protection. It is suitable for installation of HV HRC fuses up to 30 A, but a special design allow also an of HV HRC fuses of 100 A

Fuse holder type VOH is designed for installation on transformer of hermetical type with HV connectors 12(24) kV type plug-in up from 50 to 400 kVA rated power.

The holding construction allows assemblies on the transformer's cover without reaching into the distribution transformer.



Figure 9: Holding construction of fuse holder type VOH01

When choosing a type of a fuse holder following data must be specified: size and type of transformer (cover of transformer), voltage indication type (IN5, IN6) and indication design (VOH01, VOH02).

At the assembly of the fuse holder on the transformer's cover we use the tighten screw to assure the right pressure to the silicon insertion, which is between holder and transformer's bushing.

We fix the fuse holder to prevent movement when manipulating the withdrawable part. Otherwise damages on the fuse holder and transformer's bushing can occur.



Figure 10: Silicon insertion, silicon lubricant and tube for silicon venting at installation onto the transformer's bushing

The installation of the fixed part of the fuse holder on the transformer is now complete. The fuse is inserted into the withdrawable part (cover). The cover is put on the guide rails of the fixed part, then move forward to place the withdrawable contacts. The final position is fixed with the locking handle.

The procedure is repeated for every phase. The exchange procedure is going backwards. After removing the withdrawable cover one can exchange the fuse outside of the transformer substation.

After the exchange we put the cover on the fixed part.

With this the device is ready for operation.

VOH allows a very simple earthing of the cable connector when operating.

The fixed part with the fuse is dismantled. With the earthing gear we connect to the screw M10 (Figure 9).

In this way we earth the cable without reaching into the cable head.

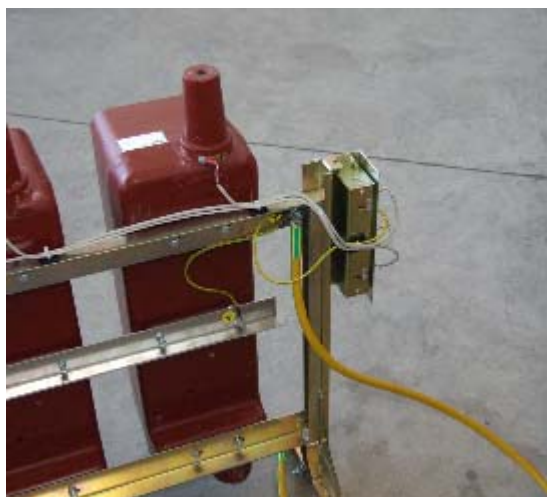

Figure 11: Screw M10 for cable earthing



Figure 13: Example of not insulated places in a transformer substation



Figure 12: Example of fuse holder type VOH 2 with two type of voltage indication.



Figure 14: An example of application of fuse holder type VOH1, which insulates the HV part in a transformer substation

5. Conclusion

After the installation of fuse holder type VOH the prefabricated compact transformer substation has a fully insulated HV part.

Due to the full insulation of voltage and current paths, there is no danger to come to a voltage breakthrough because of the creepage distances.

As example: power company Elektro Celje d.d. (data 2011) has around 55 pcs end transformer substations, where the distribution transformer is protected only by fuses.

The maintenance of the substations would decrease or even drop out by applying the fuse holder. At the same time the possibility of touching "live" parts under high voltage when working on LV side would fall away. The same goes for the HV side

The application of the fuses is the most common transformer protection against the consequences of higher values of primary current and short circuit. This kind of protection is simple, reliable and price affordable.

With application of the fuse holder type VOH we have integrated the traditional solution for transformer protection (HV HRC fuse) into the modern device concepts (transformer bushings). At the same time we have fulfill the required conditions

which are stated by the regulations about safe work on the power supply devices.

References:

- [1] Elektro Ljubljana, Interna dokumentacija
- [2] Elektro Celje, Interna dokumentacija
- [3] TSN d.o.o., Interna dokumentacija
- [4] V. Marinčič, J. Pihler, "Uporaba nove generacije visokonapetostnih varovalk za zaščito transformatorjev", 26. Posvetovanje o močnostni elektrotehniki, Kotnikovi dnevi - Radenci 2005
- [5] GIZ DISTRIBUCIJE ELEKTRIČNE ENERGIJE, »Varnostna pravila za delo na elektroenergetskih postrojih«, izdaja 2008.